

Panasonic

Operation Manual

High Speed Scanner

Model No. KV-SV50 / KV-SV50U /
KV-SV55 / KV-SV55U

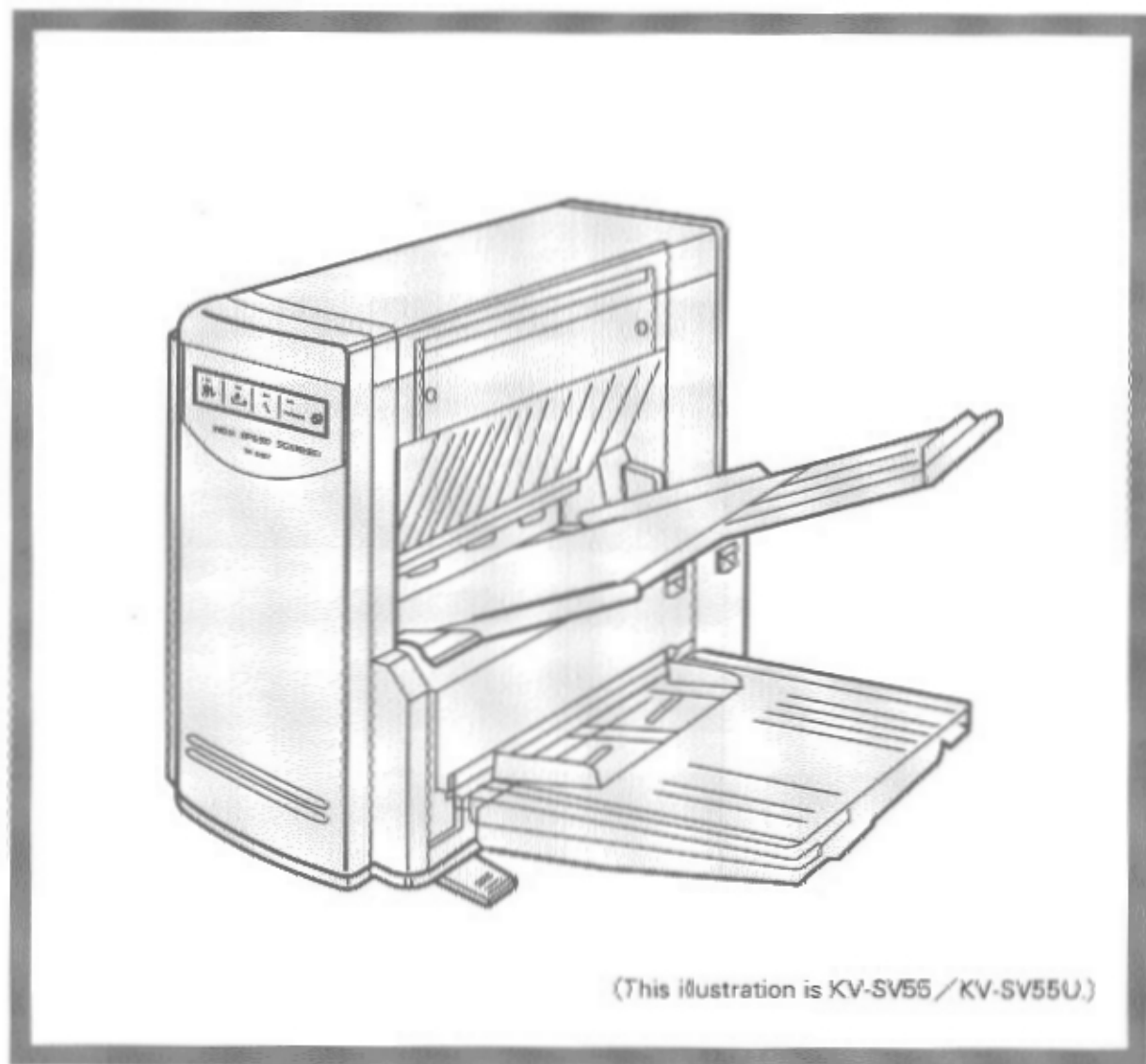

Before using this unit, please read these instructions completely.

Thank you for purchasing a Panasonic "High Speed Scanner".

Table of Contents

Notice	3
Precautions	6
Component Identification	8
Minimum Space and Installing the Stand	9
● Minimum space	9
● Installing the stand	9
Installing the Document Tray and the Exit Tray	10
Loading a Document	11
Clearing Paper Jams	13
Cleaning the Unit	14
Repacking Instructions	16
Troubleshooting	17
Specifications	18
Index	19

The information given in this Operation Manual is subject to change without notice.

This Operation Manual is printed on recycled paper.

Notice

Federal Communications Commission Requirements

(For United States only)

Note: This equipment has been tested and found to comply with the limits for a Class A digital device, pursuant to Part 15 of the FCC Rules. These limits are designed to provide reasonable protection against harmful interference when the equipment is operated in a commercial environment. This equipment generates, uses, and can radiate radio frequency energy and, if not installed and used accordance with the instruction manual; may cause harmful interference to radio communications. Operation of this equipment in a residential area is likely to cause harmful interference in which case the user will be required to correct the interference at his own expense.

FCC Warning: To assure continued FCC compliance, the user must use only the provided power supply cord and shielded interface cable. Also, any unauthorized changes or modifications to this equipment would void the user's authority to operate this device.

English

WARNING:

TO PREVENT FIRE OR SHOCK HAZARD, DO NOT EXPOSE THIS PRODUCT TO RAIN OR ANY TYPE OF MOISTURE.

THE SOCKET OUTLET MUST BE NEAR THIS EQUIPMENT AND MUST BE EASILY ACCESSIBLE.

Français

Avertissement:

Pour éviter tout risque d'incendie ou de choc électrique, ne pas soumettre cet appareil à la pluie ou à l'humidité.

"La prise secteur devra se trouver à proximité de l'appareil et être facilement accessible."

Deutsch

Warnung:

Zur Verhütung von Feuer dem und elektrischem Schlag dieses Erzeugnis nicht Regen oder sonstiger Feuchtigkeit aussetzen.

Die Steckdose muß nahe bei diesem Gerät angebracht und leicht zugänglich sein.

Für Benutzer in der BRD



Hinweis:

Der arbeitsplatzbezogene Geräuschemissionswert dieses Gerätes beträgt ≤ 70 dB(A) nach DIN 45635 Teil 19.

Notice

For your safety please read the following text carefully.

(For United Kingdom only)

This appliance is supplied with a moulded three pin mains plug for your safety and convenience. A5 amp. fuse is fitted in this plug. Should the fuse need to be replaced please ensure that the replacement fuse has a rating of 5 amps. and that it is approved by ASTA or BSI to BS1362. Check for the ASTA mark  or the BSI mark  on the body of the fuse. If the plug contains a removable fuse cover you must ensure that it is refitted when the fuse is replaced. If you lose the fuse cover the plug must not be used until a replacement cover is obtained. A replacement fuse cover can be purchased from your local Panasonic Dealer.

If the fitted moulded plug is unsuitable for the socket outlet in your home then the fuse should be removed and the plug cut off and disposed of safely.

There is danger of severe electrical shock if the cut off plug is inserted into any 13 amp. socket.

If a new plug is to be fitted please observe the wiring code as shown below. If in any doubt please consult a qualified electrician.

WARNING : This appliance must be earthed.

IMPORTANT : The wires in this mains lead are coloured in accordance with the following code.

Green-and-Yellow	: Earth
Blue	: Neutral
Brown	: Live

As the colours of the wire in the mains lead of this appliance may not correspond with the coloured markings identifying the terminals in your plug, proceed as follows.

The wire which is coloured Green-and-Yellow must be connected to the terminal in the plug which is marked with the letter E or by the Earth symbol  or coloured Green-and-Yellow.

The wire which is coloured Blue must be connected to the terminal in the plug which is marked with the letter N or coloured Black.

The wire which is coloured Brown must be connected to the terminal in the plug which is marked with the letter L or coloured Red.

How to replace the fuse :

Open the fuse compartment with a screwdriver and replace the fuse.

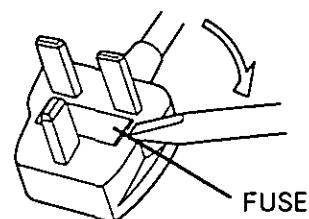

English

The product should be used only with the power cord and interface cable that are supplied by the manufacturer.

Français

Le produit ne devra être utilisé qu'avec le cordon d'alimentation et le câble d'interface fournis par le fabricant.

Deutsch

Dieses Gerät darf nur mit dem Netzkabel und dem Schnittstellenkabel verwendet werden, die vom Hersteller geliefert werden.

For roller cleaning paper

Before using the roller cleaning paper, please read these instructions completely.
Keep these instructions for future reference.

English

WARNING

- Do not drink or inhale the roller cleaning paper fluid.
- The roller cleaning paper may be harmful to sensitive skin, so please use protective gloves.
- Do not use the roller cleaning paper near a heater or open flame.
- Do not store the roller cleaning paper in direct sunlight or in a place over 40 °C (104 °F).
- Only use the roller cleaning paper to clean the rollers and scanning area.
- If you need more information about the roller cleaning paper, please refer to the Material Safety Data Sheet (MSDS).

KEEP AWAY FROM FIRE.

Français

Avertissement

- Ne pas boire ni respirer le liquide du papier de nettoyage de rouleaux fourni.
- Le papier de nettoyage de rouleaux pouvant être néfaste pour les peaux sensibles, utiliser des gants de protection.
- Ne pas utiliser le papier de nettoyage de rouleaux à proximité d'un feu ou d'une flamme vive.
- Ne pas ranger le papier de nettoyage de rouleaux en plein soleil ni à une température dépassant 40 °C (104 °F).
- Utiliser le papier de nettoyage de rouleaux exclusivement pour le nettoyage des rouleaux et de la surface de balayage.
- Pour tout renseignement complémentaire sur le papier de nettoyage de rouleaux, voir la feuille de données sur la sécurité du matériel.

NE PAS APPROCHER DU FEU.

Deutsch

WARNUNG

- Die mitgelieferte Walzenreinigungspapier-Flüssigkeit auf keinen Fall trinken oder inhalieren.
- Bitte Schutzhandschuhe tragen, da das Walzenreinigungspapier bei empfindlicher Haut Reizungen verursachen kann.
- Das Walzenreinigungspapier nicht in der Nähe von Heizgeräten oder offenen Flammen verwenden.
- Das Walzenreinigungspapier nicht in direkter Sonneneinstrahlung oder an Orten lagern, an denen Temperaturen von mehr als 40 °C erreicht werden.
- Zum Reinigen der Walzen und des Scanbereichs ausschließlich das Walzenreinigungspapier verwenden.
- Weitere Informationen zum Walzenreinigungspapier sind dem Material sicherheits-Datenblatt zu entnehmen.

VON FEUER FERNHALTEN!

Precautions

The following precautions are recommended to extend the life of the unit.

Do not place any liquids near the unit.
— Accidental spillage of a liquid into the unit may cause severe damage. If this occurs, unplug the power cord and call service.

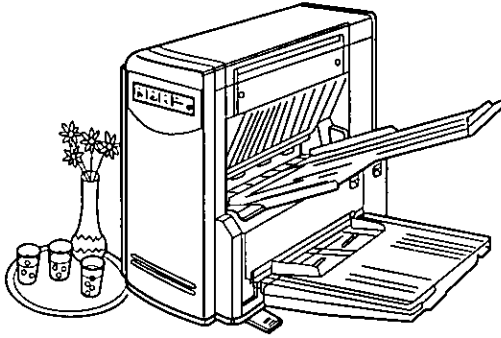

Do not place books, paper, or other items on the unit.

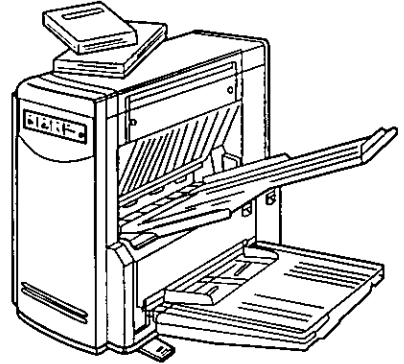

Do not operate the unit with covers open.

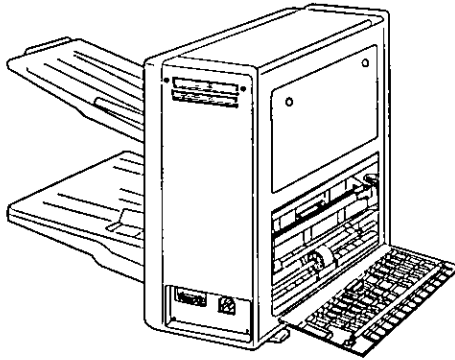

If the unit is not used for an extended period, unplug the power cord.

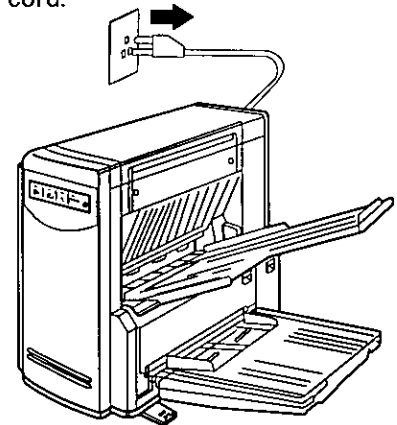

Do not place the unit on an uneven or unstable surface.

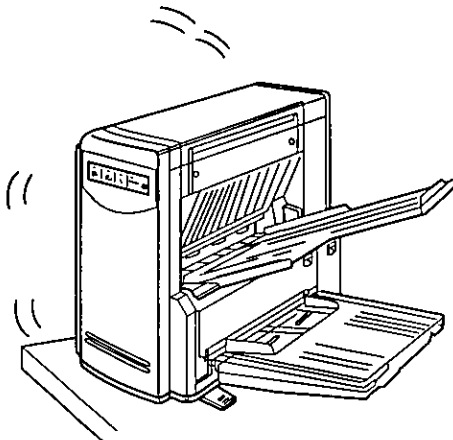

The unit must remain in a vertical position.

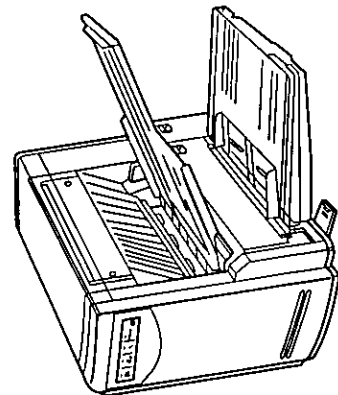

- Special care should be taken to protect the unit if it is used in a less than optimum environment such as a machine shop or a dusty or sandy area.

Operating Environment

Do not subject the unit the following conditions.

Do not place the unit in direct sunlight or in a cold draft.

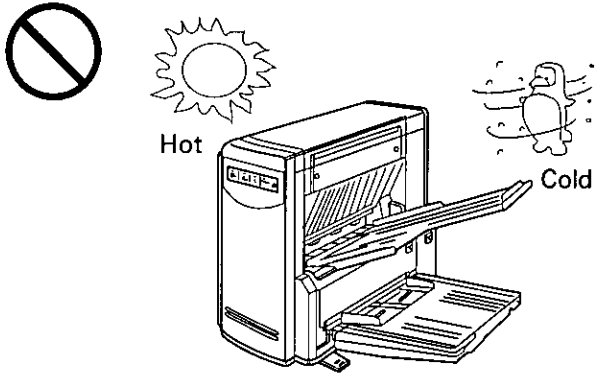

Do not place the unit in an area where there is a lot of smoke, dust, chemical fumes or vibration.

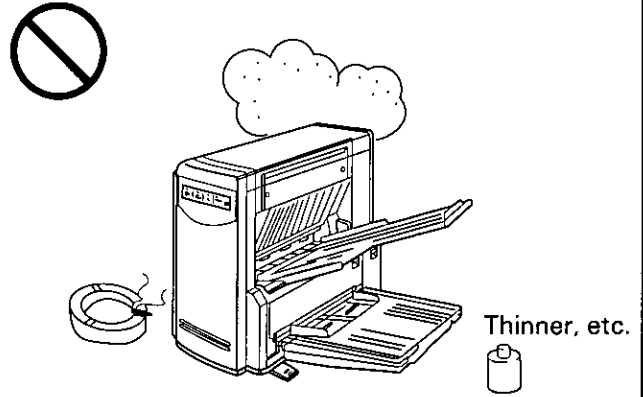

Do not place the unit near a heating appliance or an air conditioning vent. Do not place the unit in a room with extremely high or low humidity.

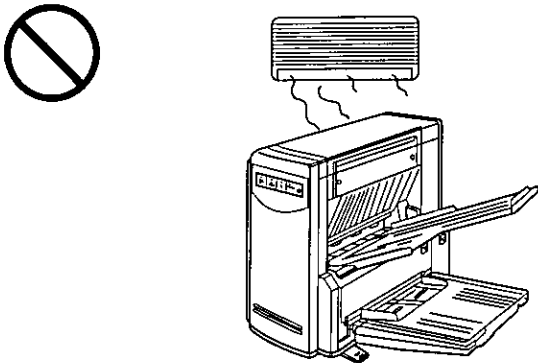

Do not place the unit near other appliances.

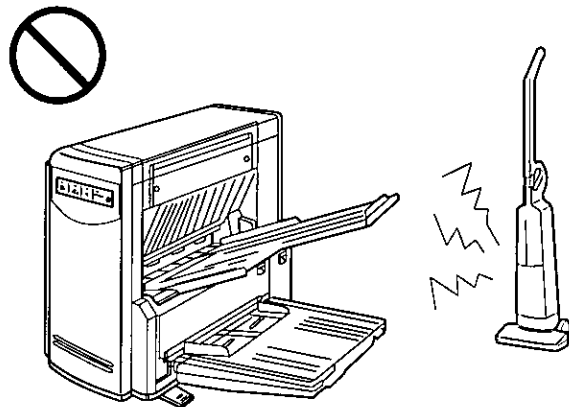

Do not place the unit on a carpet. (Static electricity can cause the unit to malfunction)

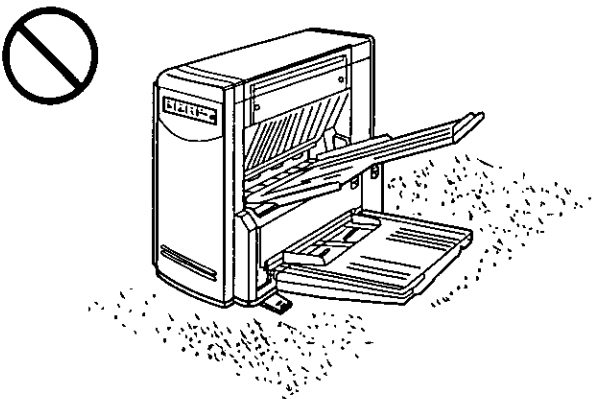

Do not disassemble the unit.

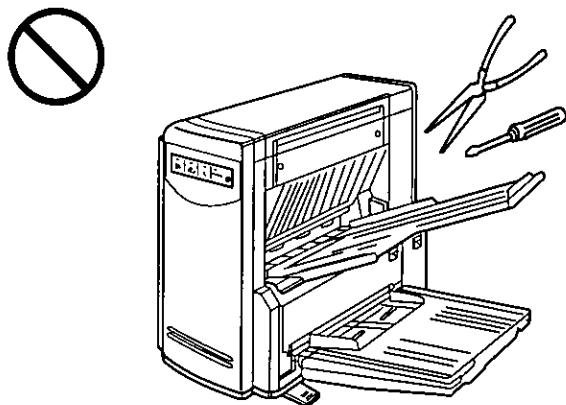

● Power Source

- Use a voltage level which does not vary more than $\pm 10\%$ from the voltage level marked on the name-plate (located on the rear of the scanner).
- Do not use an extension cord.
- This scanner should be connected to a grounded outlet.
- Do not use a line conditioner, transient suppressor or surge protector.

Component Identification

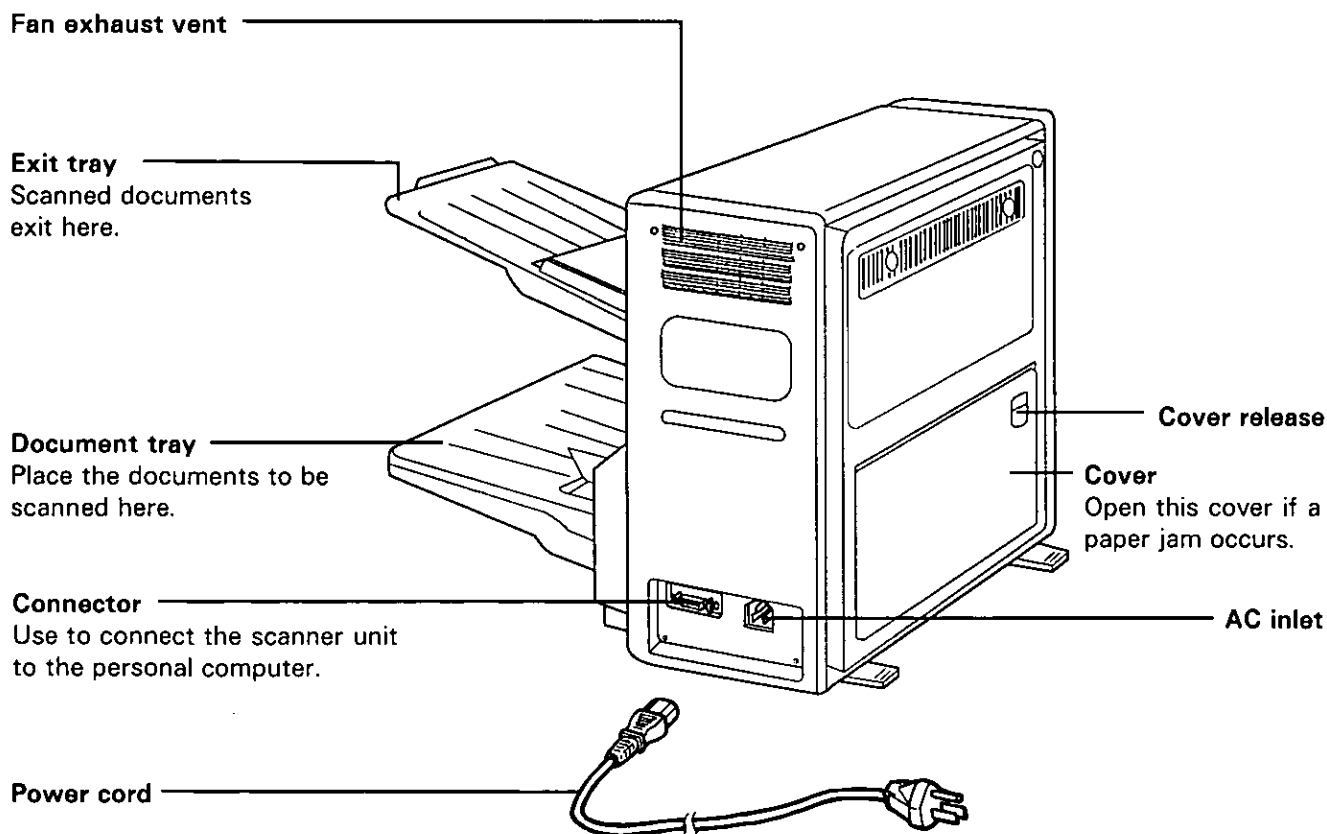
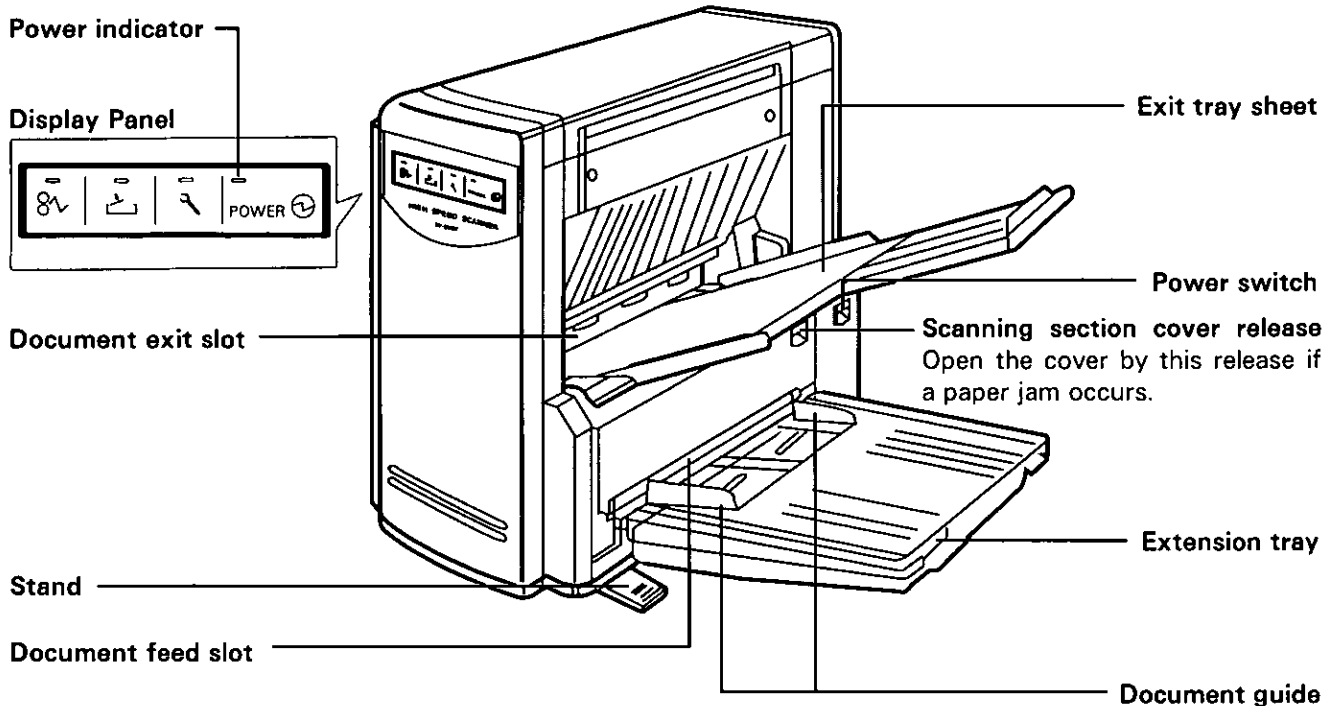

Minimum Space and Installing the Stand

Minimum space

Be sure to maintain the recommended space requirements for proper ventilation.

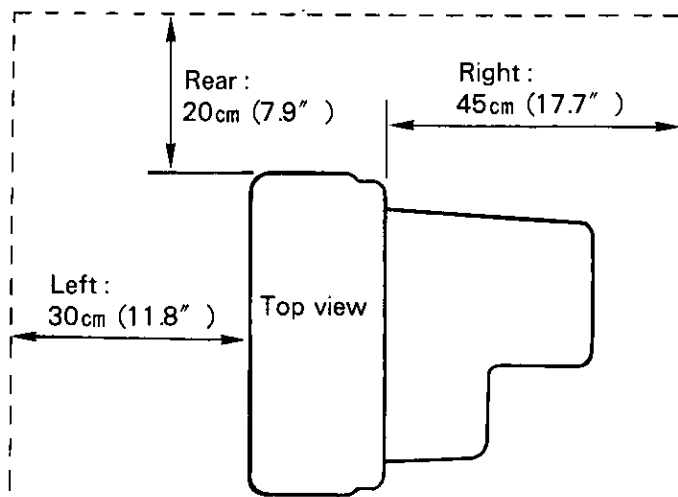

Installing the stand

1 Lift the unit.

- Do not hold the unit by the document feed slot.

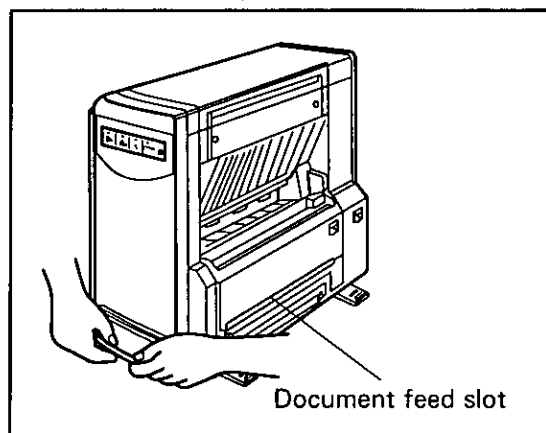

2 Turn the four feet until they appear as in the illustration.

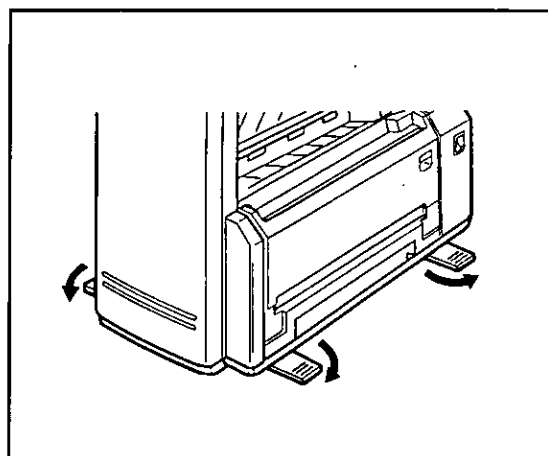

Installing the Document Tray and the Exit Tray

- 1** Align both sides of the tray with the document feed slot, then firmly insert the tray into the slot using both hands until a "click" is heard.

Caution :

Before installing the document tray, be sure to perform the following procedure.

- ① Connect the power cord.
- ② Turn the power switch on and initialize the unit for approximately 15 seconds.

- 2** Insert both ends of the exit tray into the holes at the sides of the document exit slot.

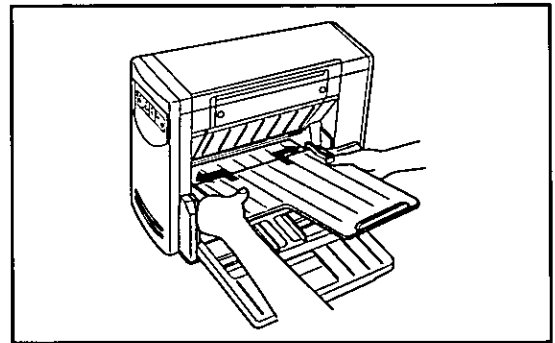
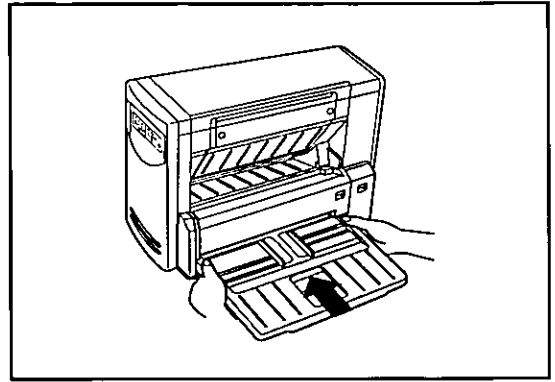

- 3** Remove the protective cover from the adhesive strip on the exit tray sheet. Place the exit tray sheet into the rear of the document exit area and attach to the exit tray.

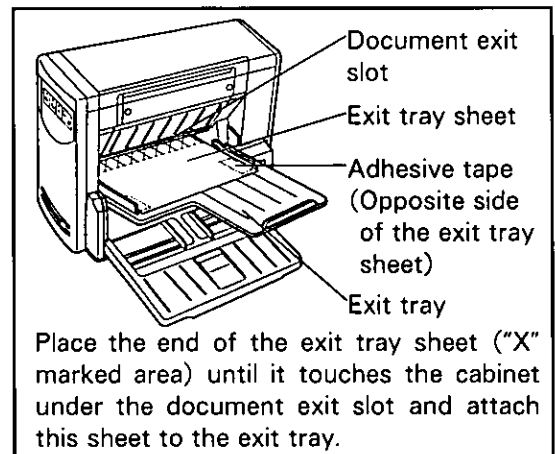

Removing the exit tray

Slightly bend the exit tray while pulling it toward you, as shown in the figure.

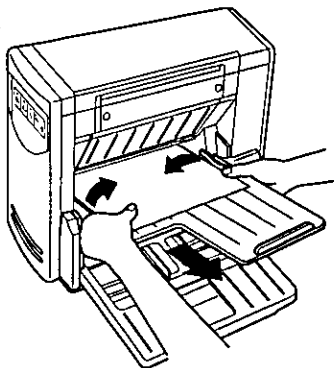

Removing the document tray

Grasp the document tray as shown in the figure, then lift slightly and pull it toward you.

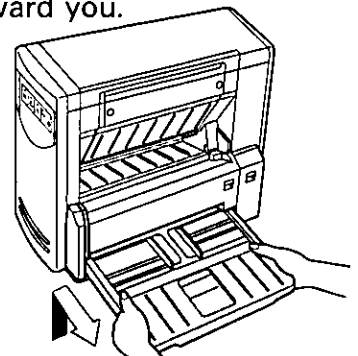

Loading a Document

1 Documents that have been stapled together or have been sitting together (as in a file folder) for some time will need to be separated.

Fan the stack of document to separate all edges.

Hold both ends of the document and bend the documents as shown in the illustration to separate the centers.

Hold the documents firmly and pull them apart as shown in the illustration to straighten.

Repeat these steps as necessary.

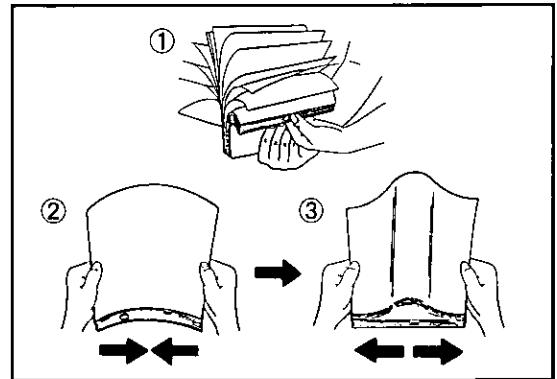

2 Carefully align the documents.

3 Place the documents on the document tray with the side to be scanned facing up, then push them in the direction of the arrow until they stop.

- Be sure to place the documents on the document tray in the lengthwise direction (see figure at right).

The amount of documents should not exceed the limit mark on the document guide. This may cause a paper jam or skew.

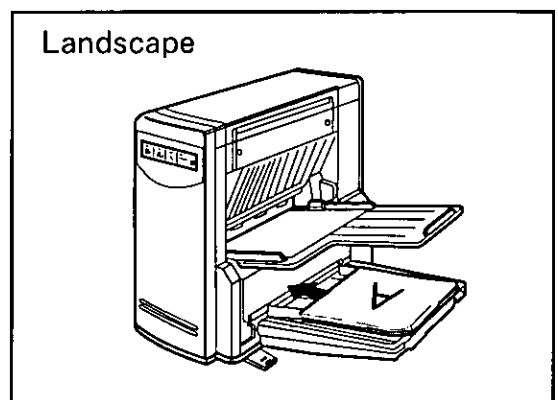
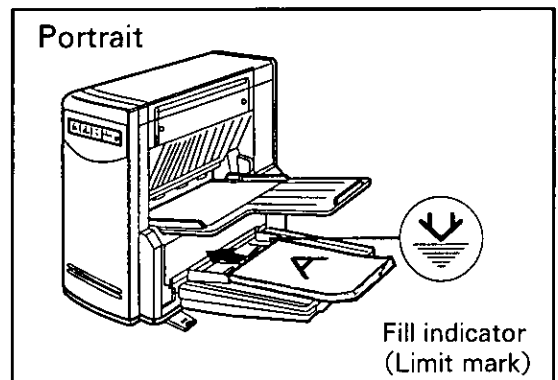

Loading a Document

4 Adjust the document guides to fit the size of the documents to be scanned.

- Make sure to properly align the documents to the document guides.

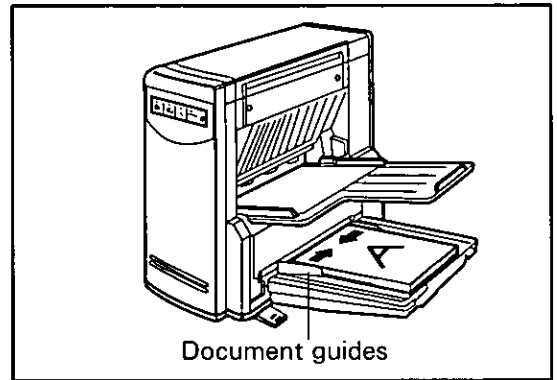

5 When using legal paper, pull out the extension tray from the document tray as shown in the illustration.

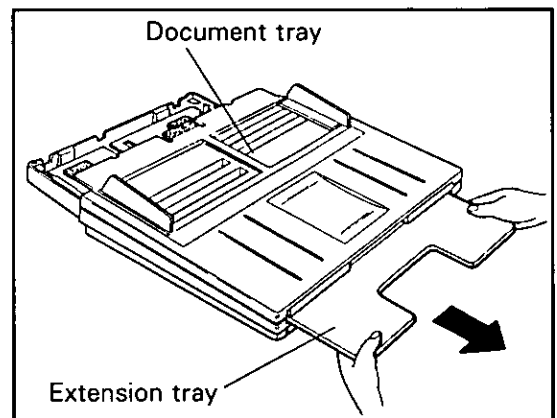

Caution :

- For thin or thick paper, scan the document using single paper feed. Also, remove the document from the exit tray after it is scanned.
- The scanner will accept 13 to 27 lb paper for continuous scanning and 11 to 34 lb paper for a single scan.
- You can load up to 80 sheets of 20 lb paper (limit mark of the document guide). Never allow the amount of documents in the tray to exceed the fill indicator. Reduce the number of documents in the tray if they are thick, creased, or curled.
- Be sure to remove the document from the exit tray after it is scanned.
- In cases where very fragile documents are to be scanned, it is recommended to make a copy and use the copy to scan into the unit.

Types of Documents to Avoid :

- OHP sheets, other plastic film, cloth, or metallic sheets.
- Paper with irregularities such as tabs, staples, paste etc.
- Documents with wet ink.
- Thick or irregular documents such as envelopes, ups, etc.
- Copying paper such as carbons or carbonless paper.
(Chemically treated carbonless forms)

Note : Scanning chemically treated paper will result in premature wear of paper feed roller.

- Damaged or wrinkled documents.
- Unusually shaped documents.
- Tracing paper.

Note : Use only Single Scan mode for coated documents or photos.

Clearing Paper Jams

Torn documents, thin documents or documents that are creased at the leading edge may cause paper jamming. If a paper jam occurs (the lamp "8v" to indicate "Paper jam" will light on the Display Panel), remove the jammed sheet according to the following procedure.

● Removing paper jams from the scanner

Remove the exit tray, document tray and open the scanning section cover by inserting your finger into the cover release and gently pulling up the tab while pushing down the cover slightly.

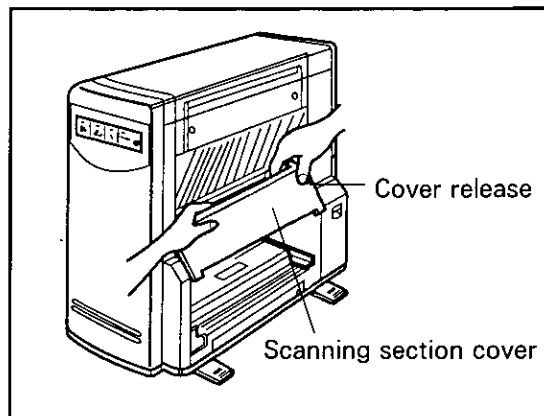

● If the paper cannot be removed by pulling it forward

Open the cover and then open the scanning section cover inside by pulling the tab toward the front.

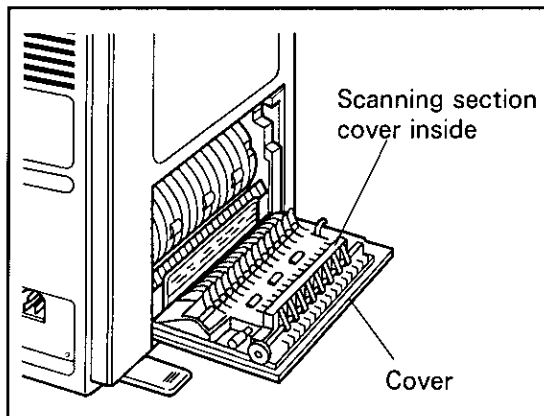

Cleaning the Unit

Outside of the Unit :

- at least once a month

- 1** Turn the power OFF.
- 2** Clean the cover with a soft cloth.
- 3** Remove dirt and dust from the fan exhaust vent with a brush.

Inside of the Scanner :

- Please clean the unit once a month, when 50,000 sheets or more are fed into the unit, or at the earliest opportunity.
- When you experience paper jamming or multiple sheet feeding problems, follow steps 1 through 4 for cleaning the rollers and paper sensors.
- When black vertical lines appear on the scanned image, please follow steps 1 and 5 for cleaning the reading element.

- 1** Turn the power OFF.
- 2** When a jam or misfeed occurs, clean the rollers (parts ① to ⑦) with a clean cloth as shown in the figure on the right.

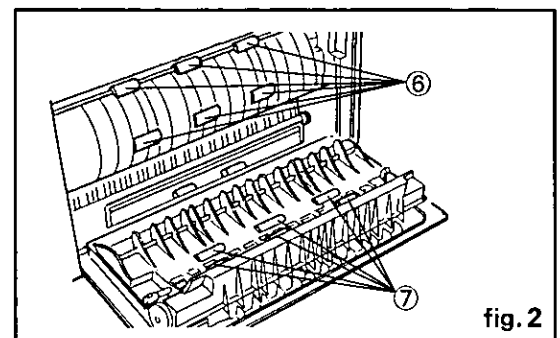
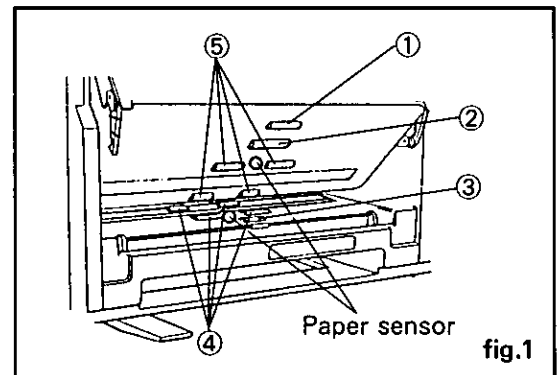

3 When the parts are especially dirty, use the included "Roller Cleaning Paper", wipe clean all of the dirty parts while rotating the roller in the direction of the arrows shown in the figure.

- When feeding of multiple sheets occurs often clean the rollers (parts ①, ② and ③) with the included roller cleaning paper.

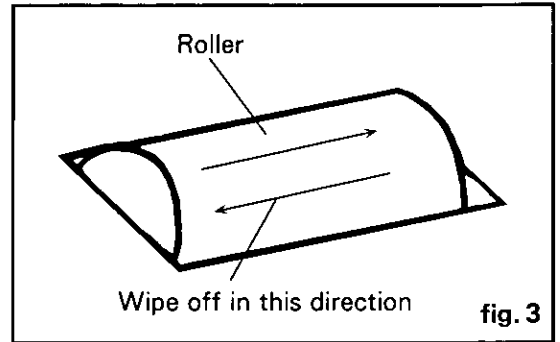

4 Clean the paper sensors shown in fig. 1, using a dry, clean cloth.

5 When the scanned image has vertical black lines, wipe the glass and white reference plate clean using a dry, clean cloth as shown in the figure on the right.

- When especially dirty, use the included roller cleaning paper to wipe clean.

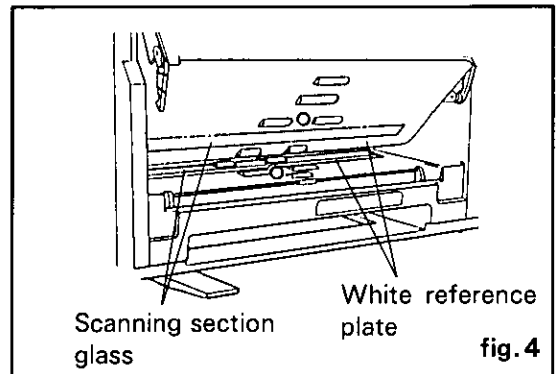

Note for the roller cleaning paper;

Open the bag by the dotted line and take the roller cleaning paper out. (See fig. 5.)

- If the opened bag is left for a period of time, the alcohol will vaporize. Please use the roller cleaning paper immediately after opening the bag.

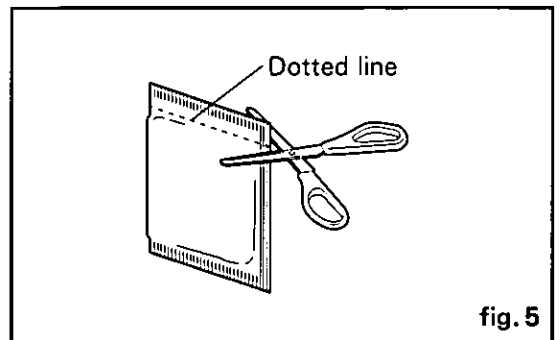

※The roller cleaning paper (Model No. KV-SS03) is available at the dealer where you purchased your scanner.

Repacking Instructions

It is highly recommended that you keep the original carton and ALL packing materials. Should you need to transport or ship your scanner, please follow these instructions.

Please Note :

- Please use the original carton and all of the original packing materials. If you do not have the original packing material, these are available from Panasonic. Please refer to your servicing dealer, or call 1-800-833-9626 (KV-SV50/KV-SV55 only).
- Improper repacking of the scanner may result in a service charge to repair the unit.
- The scanner should be handled in the upright (vertical) position.

Material Required :

- Original Scanner Carton & Packing Materials
- Shipping Tape and Scissors

1 Disconnect your scanner from the electrical outlet and the interface cable.





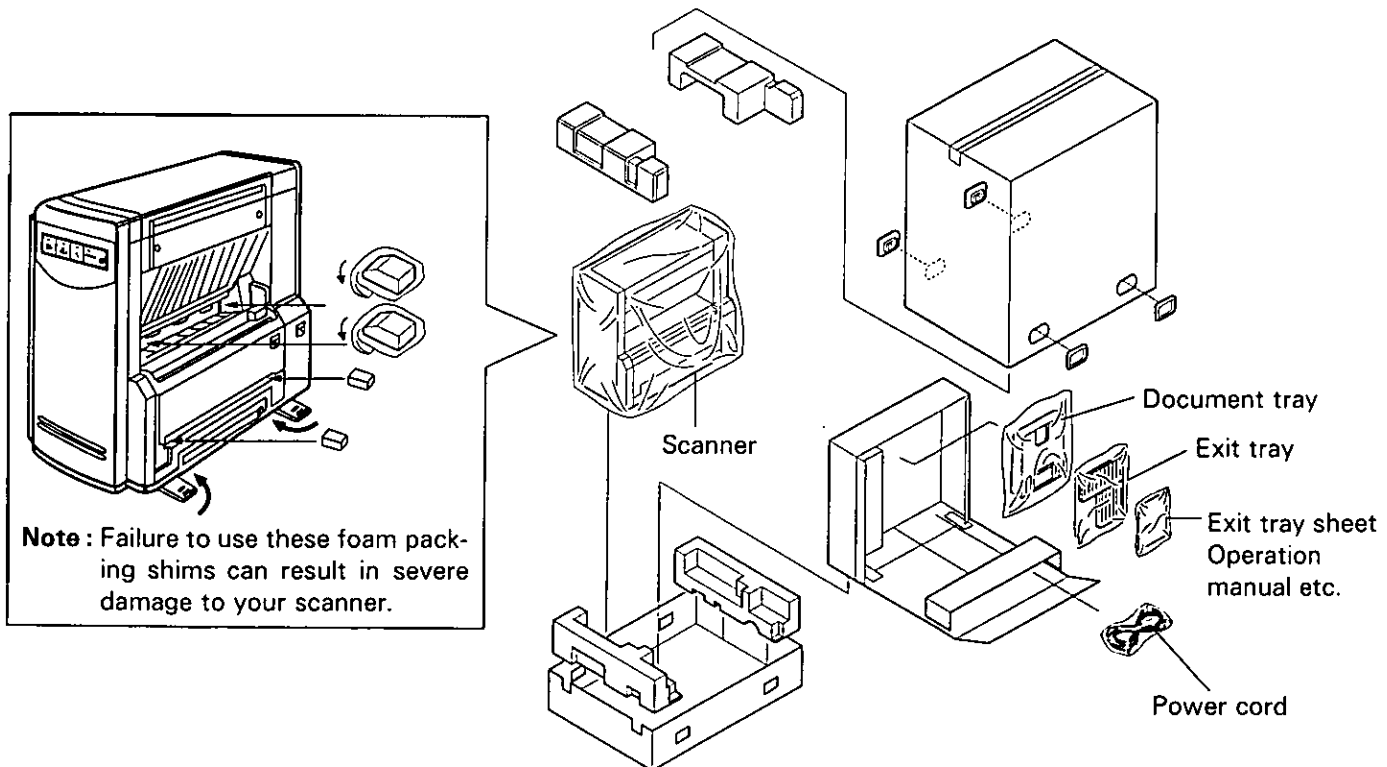

2 Close the scanner stands into their shipping positions.

3 Packing the scanner.



Troubleshooting

If a problem occurs while the unit is being used, first check the following items. If the unit still malfunctions, switch it OFF, and call service.

Symptom	Possible Cause	Remedy
Power indicator does not light when the power switch is turned ON.	The power plug has come out.	Insert the power plug firmly.
	The fuse has blown.	Pull out the power plug, then call service. 
	Foreign matter is lodged in the fan, preventing it from rotating.	
Scanning takes a long time to start, or does not take place at all.	The fluorescent lamp in the scanner has reached the end of its life.	Call service. 
	The ambient temperature is less than 15°C (59°F).	Use the unit in a room where the ambient temperature is between 15°C and 30°C (59°F and 86°F).
Documents are not fed while scanning.	 Documents are not loaded correctly.	Align the front edges of the document, place them firmly against the document feed slot, then start scanning.
	 Various covers are open.	Close the covers firmly.
	 There is a paper jam.	Remove the jammed paper (see page 13).
	 The rollers are dirty.	Clean the rollers (see page 14).
Multiple sheet feeding problem occurs.	The rollers are dirty.	Clean the rollers (see pages 14 and 15).
Document stops during a scan.	The document is creased or torn, or has a length of more than legal or less than 91 × 55mm (3.6 × 2.2in).	Make a copy of the document on paper of the specified size [between 91 × 55mm (3.6 × 2.2in.) and Legal] and scan the copy.
Document stops or is not fed smoothly during a scan.	The rollers are dirty.	Clean the rollers (see page 14).
The scanned document is blank.	The document to be scanned was loaded face down (upside down).	Load the document correctly.
The scanned document is completely blank.	The fluorescent lamp in the scanner has reached the end of its life.	Call service. 
Scanned document is skewed.	The document guides were not touching the edges of the document, or the documents was skewed when loaded.	Set the document guides or the document correctly.
Vertical lines appear on the scanned document.	The white reference plate, scanning section glass or the rubber rollers are dirty.	Wipe the dirty part with a clean cloth (refer to page 14).
The computer cannot connect to the scanner.	The computer cannot recognize to the scanner.	Turn the power of the computer OFF. Turn the power of the scanner ON, then turn the power of the computer ON again.

Specifications

Item		Model No.	KV-SV50/ KV-SV55	KV-SV50U/ KV-SV55U
Scanner	Scanning face	KV-SV50 series : Simplex scanning KV-SV55 series : Duplex scanning		
	Scanning method	KV-SV50 series : CCD image sensor KV-SV55 series : CCD image sensor (front) and contact-type image sensor (reverse)		
	Readout speed	KV-SV50 series : Approx. 40 sheets/min. (Letter, fed lengthwise, 200 dpi) KV-SV55 series : Approx. 20 sheets/min. (Letter, fed lengthwise, 200 dpi)		
	Resolution	Main scanning direction : 150 to 300dpi (10 dpi step) Sub-scanning direction : 5.9 to 11.8 lines/mm [150 to 300dpi (10 dpi step)]		
	Tonal gradation	Binary mode, 64-step gradation (dither) mode, 64-step gradation (error diffusion) mode		
	Paper	Size	55×91mm (2.2×3.6 in) to Legal [216×356mm (8.5×14 in.)]	
Thickness		Single paper feed : 0.05 to 0.2mm (2.0 to 7.9 mils) Continuous paper feed : 0.06 to 0.15 mm (2.4 to 5.9 mils) Note : 1 mil = 1/1000 in.		
Weight		Single paper feed : 40 to 127 g/m ² (11 to 34 lbs.) Continuous paper feed : 50 to 100 g/m ² (13 to 27 lbs.)		
Unit	External dimensions (Width×Depth×Height)	568×450×390mm (22.4×17.7×15.4 in.)		
	Mass (Weight)	14kg [14kgf (31 lbs.)]		
	Power requirement	120V AC, 60Hz	220V–240V AC, 50/60Hz	
	Power consumption	Maximum, (scanning)	1.3A	0.8A
Minimum, (standby)		0.5A	0.3A	
Operating Environment	Operating temperature and humidity	15°C to 30°C (59°F to 86°F), 30% to 80%RH		
Storage Environment	Storage temperature and humidity	0°C to 35°C (32°F to 95°F), 10% to 80%RH		
Accessories	Document tray, Exit tray, Exit tray sheet, Power cord, Operation manual and Installation manual, Roller cleaning paper			

"Weight in pounds" represents the weight of 500 [17×22 inches (432×559mm)] sheets.

Index

A

AC inlet 8

C

Connector 8
Cleaning the unit 14
 Fan exhaust vent 14
 Paper sensor 14
 Scanning section glass 15
 White reference plate 15
Component identification 8
Cover 8
Cover release 8

D

Display panel 8
Document exit slot 8
Document feed slot 8, 9
Document tray 8, 10, 12
Document guide 8, 12

E

Exit tray 8, 10
Extension tray 8, 12

F

Fan exhaust vent 8
Fill indicator (Limit mark) 11

I

Installation
 Document tray 10
 Exit tray 10
 Stand 9

P

Power indicator 8
Power switch 8
Power cord 8
Power source 7
Paper jam 13

S

Stand 8, 9
Scanning section cover release 8
Scanning section cover 13
Specifications 18

T

Troubleshooting 17

Panasonic Communications & Systems Company
Division of Matsushita Electric Corporation of America
Two Panasonic Way, Secaucus, New Jersey 07094

Panasonic Canada Inc.
5770 Ambler Drive, Mississauga, Ontario, L4W2T3

Matsushita Electric Industrial Co., Ltd.
Central P. O. BOX 288, Osaka 530-91, Japan